

# MULTITEL 160ALU

NISSAN CABSTAR 35.11 / 35.13 MY06

Ente	Rev.	Descrizione	Data	Dis.	Contr.	Ap.A0
MRK	0	EMISSIONE	01-07-08	P.F.		
INGOMBRO - SCHEDA 54/1 - Rev. 0 - 15/12/00						

D39585

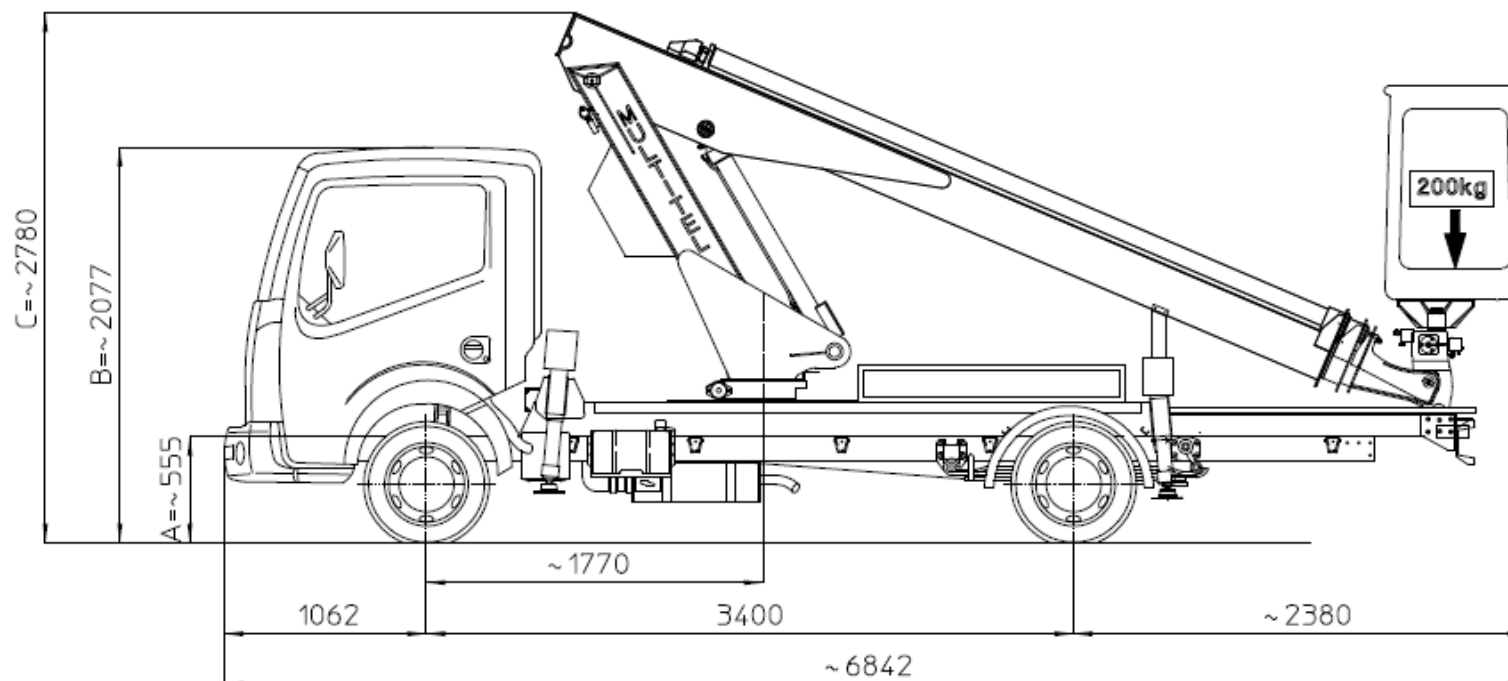

Le quote A-B sono relative alle dimensioni dell'autocarro, quindi devono essere verificate sullo stesso.  
La quota C (altezza totale) e' subordinata alle quote A-B e non comprende eventuali parti flessibili.

Les cotes A-B sont relatives aux dimensions du porteur, donc elles doivent être vérifiées sur le porteur même.  
La cote C (hauteur totale) est subordonnée aux cotes A-B est indiquée hors flexibles.

The dimensions A-B are related to the truck sizes, therefore they must be verified.  
The dimension C (total height) is subject to A-B and does not include hoses.

Die Abmessungen A-B betreffen die Fahrzeugmasse, daher sollen sie geprüft werden.  
Die Abmessung C (Gesamthöhe) hängt von A-B Abmessungen ab, die schläuche sind ausgeschlossen.

	TIPO DI STABILIZZAZIONE	PORTATA CESTELLO (kg)	
		200 kg	
DIAGRAMMI DI LAVORO	PIEDI IN SAGOMA	D31059	
	PIEDI PARZIALI		
	PIEDI ESTESI		
	SOTTOPONTE		
CARICO UTILE DIS. STABILIZZAZIONE		D39724	
AUTOCARRO	1°ASSE	2°ASSE	
TARE A VUOTO	1180 kg	520 kg	
MASSIMI AMMESSI	1750 kg	2200 kg	
P.T.T.		3500 kg	
NOTE:			

# MULTITEL 160ALU

NISSAN CABSTAR 35.11/35.13 MY06

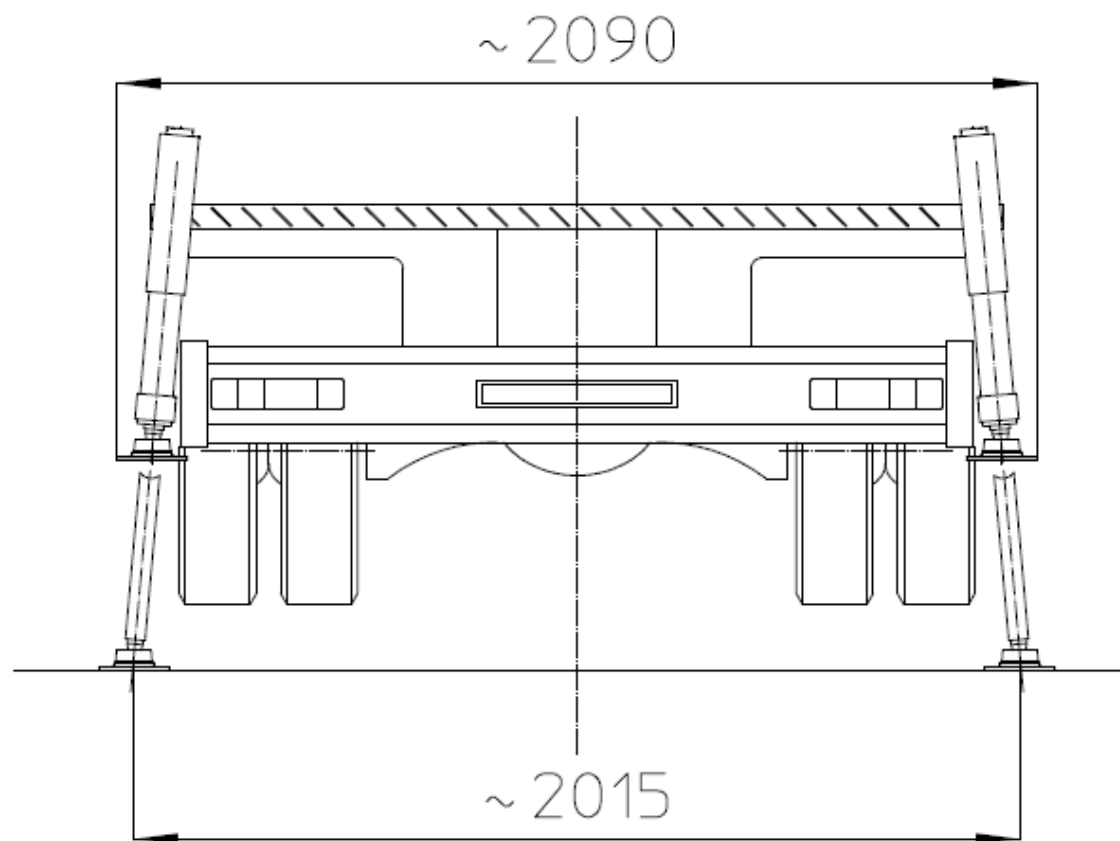

D39724

Ente	Rev.	Descrizione	Data	Dis.	Contr.	Ap.AQ
MRK	0	EMISSIONE	07-02-07	W.B.		
INGOMBRO - SCHEDA 54/1 - Rev. 0 - 15/12/00						

# MULLER BOBQU

Ente	Rev.	Descrizione	Data	Dis.	Cont.	App.
MRK	0	EMISSIONE	07-09-01	W.B.		

DIAGRAMMA - SCHEDA 54/2 - Rev. 0 - 15/12/00

D31059

SBRACCIO DI LAVORO	7.5 m	10.2 m ±5%
WORKING OUTREACH	7.5 m	10.2 m ±5%
DEPORT DE TRAVAIL	7.5 m	10.2 m ±5%
SEITLICHE REICHWEITE	7.5 m	10.2 m ±5%

200Kg

80Kg

